

TOLERANCES acc. to ISO / TOLERANSEER enl. ISO
 Applicable where no tolerance is indicated.
 Gælder når tolerans er direkte udsat
 For machining / For bearbejning: ISO 2768-mK
 For welding / For svejsning: SS-EN ISO 13920-BF
 Surface finish acc. to ISO 1302 Machined surfaces.
 Yfjæmhet enligt ISO 1302. För bearbetade ytor.

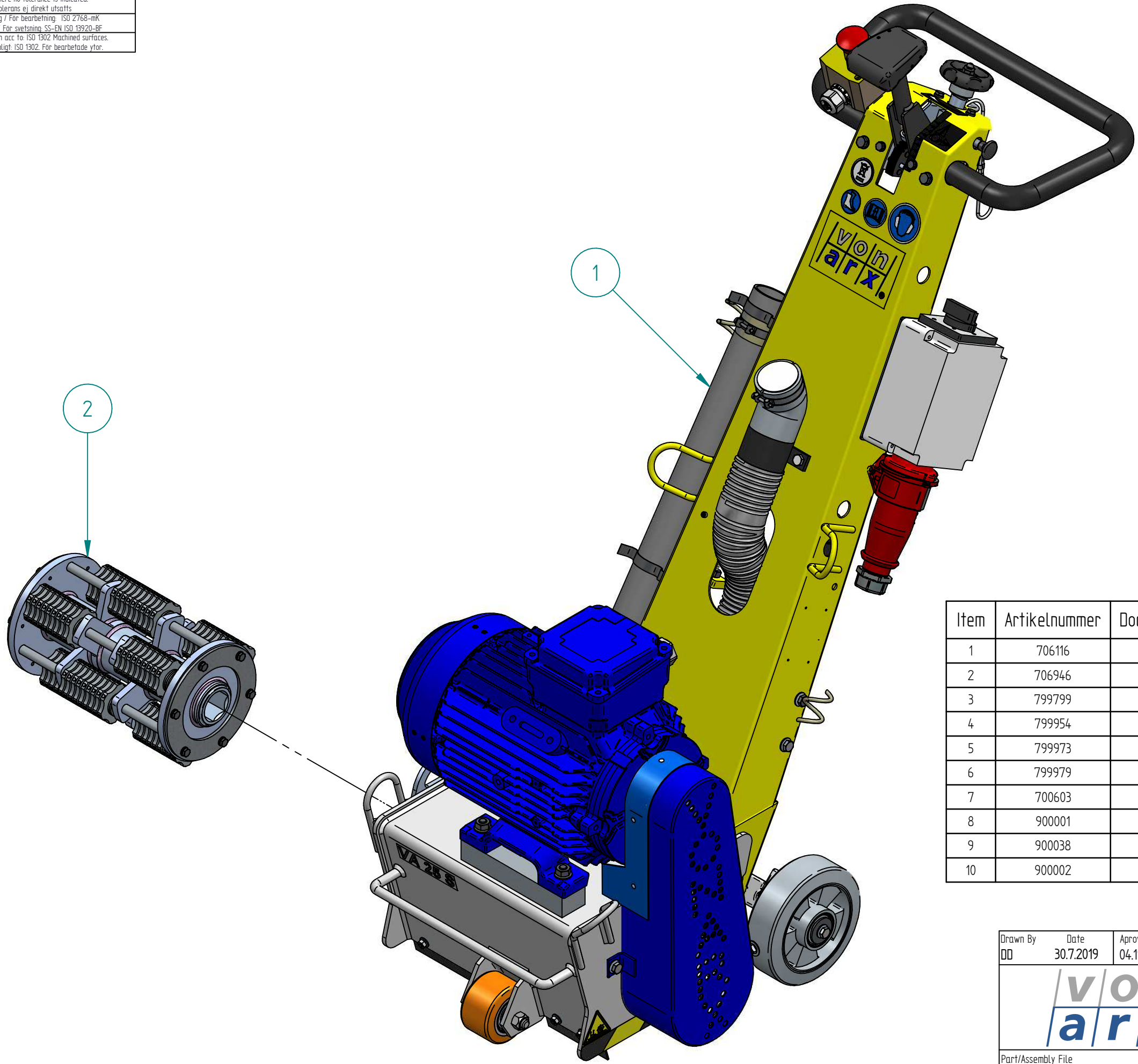

Item	Artikelnummer	Document Number	Title	Quantity
1	706116	644.20.00	VA 25 S WITH ELECTRIC MOTOR 38	1
2	706946	652.04.17	DRUM WITH HEXAGONAL CUTTERS 54	1
3	799799		EU - ATTENTION OF CONFORMITY	1
4	799954		BROCHURE: QUALITY PRODUCTS	1
5	799973		OPERATING MANUAL VA25S	1
6	799979		WARRANTY CARD FR	1
7	700603		TUBE MOLYKOTE BR2 PLUS	0.01
8	900001		NAYLON BAG WITH TIE 300 X 470mm	1
9	900038		CARTON BOX FOR PALLET 119x79x120h	1
10	900002		EURO PALLET 120/80	1

Drawn By DD		Date 30.7.2019	Approved Date 04.11.2019	Approved By MS	Material	Dimension
Units : mm		SIZE A3				
			Description FR 200 WITH ELECTROMOTOR 230 V		Article Number 706289	
			DWG NO 644.20.17			
Part/Assembly File 6442017.asm			sheet 1	of 1		Rev.

THE INFORMATION CONTAINED IN THIS DRAWING IS THE SOLE PROPERTY OF VON ARX EOOD. REPRODUCTION IN PART OR WHOLE WITHOUT THE WRITTEN PERMISSION OF VON ARX EOOD IS PROHIBITED.