

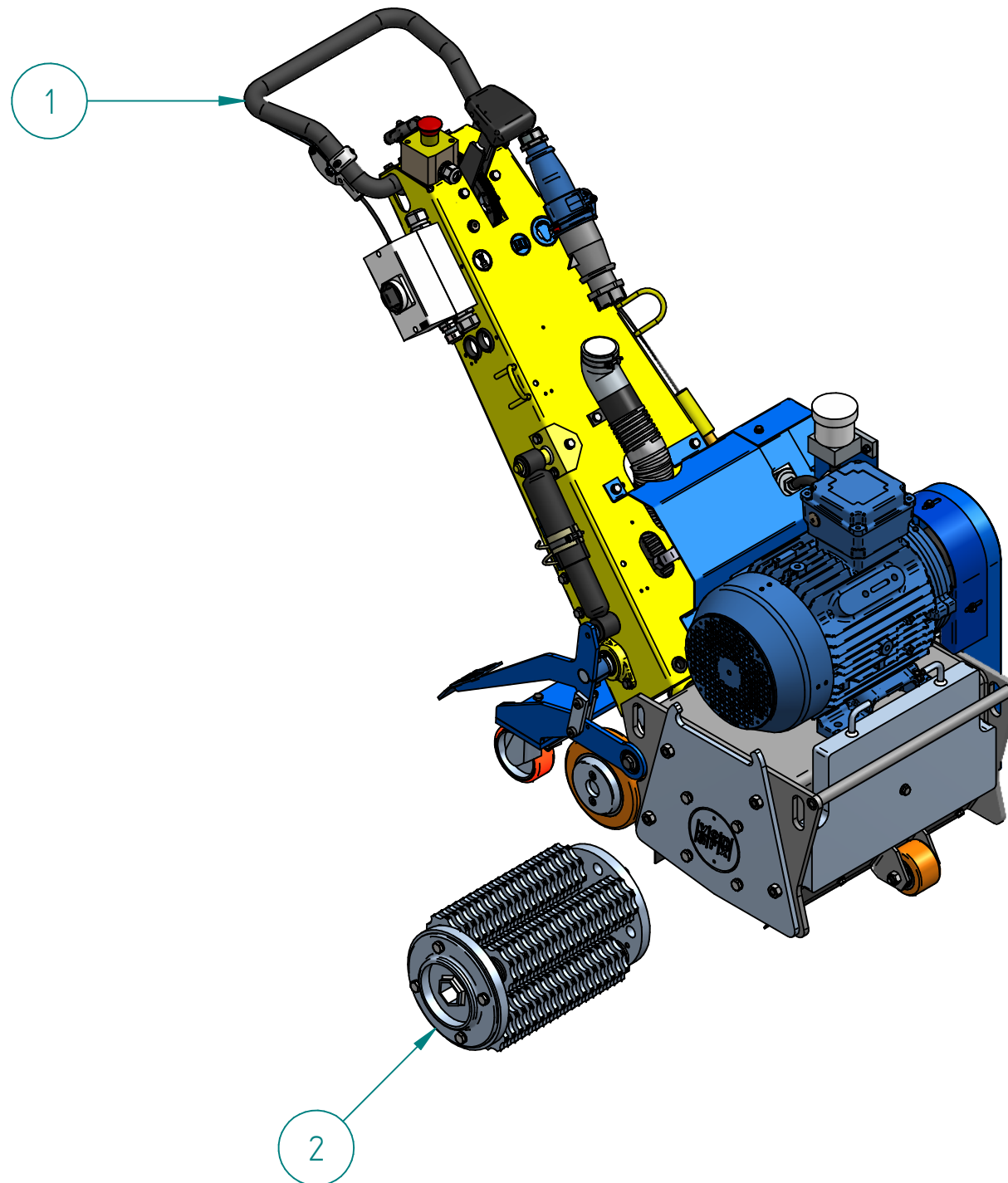

TOLERANCES acc. to ISO / TOLERANSER enl. ISO  
 Applicable where no tolerance is indicated.  
 Gäller där tolerans ej direkt utsatts  
 For machining / For bearbetning: ISO 2768-mK  
 For welding / For svetsning: SS-EN ISO 13920-BF  
 Surface finish acc. to ISO 1302 Machined surfaces.  
 Ytjämnhet enligt ISO 1302. För bearbetade ytor.

Item	Artikelnummer	Document Number	Title	Quantity
1	800019	800019	VA 30 SH ELECTRIC 7.5KW 230V	1
2	701691	630.03.12	DRUM WITH OCTAGONAL CUTTERS FO	1
3	799799		EU - ATTENTION OF CONFORMITY	1
4	799950		OPERATING MANUAL VA 30 SH	1
5	799954		BROCHURE: QUALITY PRODUCTS	1
6	799979		WARRANTY CARD FR	1
7	900074		TUBE MOLYKOTE BR2 PLUS	0.005
8	900001		NAYLON BAG WITH TIE 300 X 470mm	1
9	900039		CARTON BOX FOR PALLET 139x79x120h	1
10	900063		EURO PALLET 140/80	1

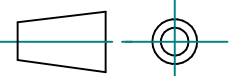

THE INFORMATION CONTAINED IN THIS DRAWING IS THE SOLE PROPERTY OF VON ARX. EOOD REPRODUCTION IN PART OR WHOLE WITHOUT THE WRITTEN PERMISSION OF VON ARX. EOOD IS PROHIBITED.

Material				Dimension	
Drawn By MS	Date 26/08/2019	Approved Date 07/11/2020	Approved By MS	Units : mm	SIZE A3
		Description VA 30 SH 7.5kw, 3X230V, 60Hz		Article Number 800014	
				DWG NO 800014	
Part/Assembly File 800014.asm			sheet 1	of 1	
				Rev.	