

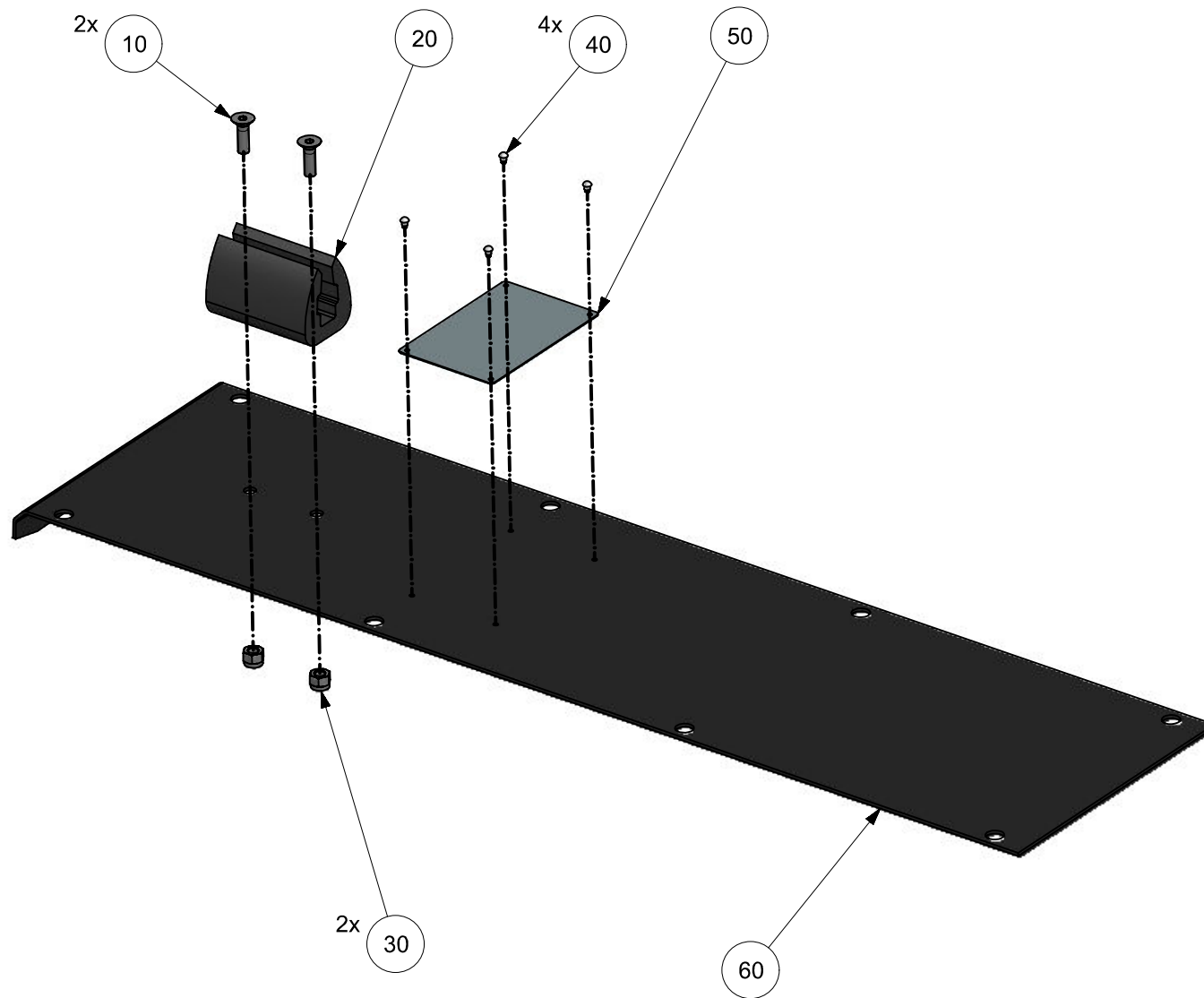

60	P7000527/01	PLATE	COVER FRONT	-	1
50	P7001160/00	PRODUCT PLATE	G4	-	1
40	S012956/00	SCREW	2.49X3.17 HD URH UNI 7346	BN 896	4
30	S106881/00	DIN_982,M5,8.8	Prevailing Torque Type Hexagon Nut, DIN 982-1987,M5,8.8	NX Standard Part	2
20	P7001406/00	MOUNT BASE	ALLEN KEY HOLDER	-	1
10	S007586/00	DIN_7991,M5x16,4.8	Hexagon Socket Countersunk Head Screw, DIN 7991-1986,M5x16,4.8	NX Standard Part	2
NO.	TITLE	NAME	DESCRIPTION	NOTES	QTY

ART.NR. 7001441 -	REV. 00	PROJECTION 	MATERIAL		
TITLE COVER FRONT ASSY - COVER FRONT ASSY			FINISH -		
NOTES:-			DESIGNER	PALLAG DESIGN	PROJECT P2209-JLM - Floor Grinder
			DATE		UNLESS OTHERWISE SPECIFIED: DIMENSIONS ARE IN MILLIMETERS, FOR UNDEFINED MACHINING TOLERANCES USE ISO 2768-MK, FOR WELDING SS-EN ISO 13920-BF, MACHINED SURFACE FINISH ACCORDING TO ISO 1302, FOR UNDEFINED GEOMETRY SEE 3D MODEL.
			LAST CHANGE	PALLAG DESIGN	
			DATE	09-Apr-2024	
			STATUS		
NO.	CHANGE	DATE	DESIGNER	SHEET 1 / 2	SIZE: A3

THE INFORMATION CONTAINED  
IN THIS DRAWING IS THE SOLE  
PROPERTY OF PUVAC HUNGARY KFT.  
REPRODUCTION IN PART OR WHOLE  
WITHOUT THE WRITTEN PERMISSION  
OF PUVAC HUNGARY KFT. PROHIBITED.



THE INFORMATION CONTAINED  
IN THIS DRAWING IS THE SOLE  
PROPERTY OF PUVAC HUNGARY KFT.  
REPRODUCTION IN PART OR WHOLE  
WITHOUT THE WRITTEN PERMISSION  
OF PUVAC HUNGARY KFT. PROHIBITED.

ART.NR. 7001441 -		REV. 00	PROJECTION ⊕	MATERIAL	
TITLE COVER FRONT ASSY - COVER FRONT ASSY				FINISH -	
NOTES: -			DESIGNER	PALLAG DESIGN	PROJECT
			DATE		P2209-JLM - Floor Grinder
			LAST CHANGE	PALLAG DESIGN	UNLESS OTHERWISE SPECIFIED: DIMENSIONS ARE IN MILLIMETERS, FOR UNDEFINED MACHINING TOLERANCES USE ISO 2768-MK, FOR WELDING SS-EN ISO 13920-BF, MACHINED SURFACE FINISH ACCORDING TO ISO 1302, FOR UNDEFINED GEOMETRY SEE 3D MODEL.
			DATE	09-Apr-2024	
			STATUS		
NO.	CHANGE	DATE	DESIGNER	SHEET 2 / 2	SIZE: A3